

Outline



- Part 3: Models of Computation
 - FSMs
 - Discrete Event Systems
 - CFSMs
 - **Data Flow Models**
 - Petri Nets
 - The Tagged Signal Model



Data-flow networks

- A bit of history
- Syntax and semantics
 - actors, tokens and firings
- Scheduling of Static Data-flow
 - static scheduling
 - code generation
 - buffer sizing
- Other Data-flow models
 - Boolean Data-flow
 - Dynamic Data-flow



Data-flow networks

- Powerful formalism for data-dominated system specification
- Partially-ordered model (no over-specification)
- Deterministic execution independent of scheduling
- Used for
 - simulation
 - scheduling
 - memory allocation
 - code generation

for Digital Signal Processors (HW and SW)



A bit of history

- Karp computation graphs ('66): seminal work
- Kahn process networks ('58): formal model
- Dennis Data-flow networks ('75): programming language for MIT DF machine
- Several recent implementations
 - graphical:
 - Ptolemy (UCB), Khoros (U. New Mexico), Grape (U. Leuven)
 - SPW (Cadence), COSSAP (Synopsys)
 - textual:
 - Silage (UCB, Mentor)
 - Lucid, Haskell



Data-flow network

- A Data-flow network is a collection of **functional nodes** which are connected and communicate over **unbounded FIFO queues**
- Nodes are commonly called **actors**
- The bits of information that are communicated over the queues are commonly called **tokens**



Intuitive semantics

- (Often stateless) actors perform computation
- Unbounded FIFOs perform communication via sequences of tokens carrying values
 - integer, float, fixed point
 - matrix of integer, float, fixed point
 - image of pixels
- State implemented as self-loop
- Determinacy:
 - unique output sequences given unique input sequences
 - Sufficient condition: blocking read
(process cannot test input queues for emptiness)



Intuitive semantics

- At each time, one actor is **fired**
- When firing, actors **consume** input tokens and **produce** output tokens
- Actors can be fired only if there are enough tokens in the input queues

Intuitive semantics

- Example: FIR filter
 - single input sequence $i(n)$
 - single output sequence $o(n)$
 - $o(n) = c1 i(n) + c2 i(n-1)$

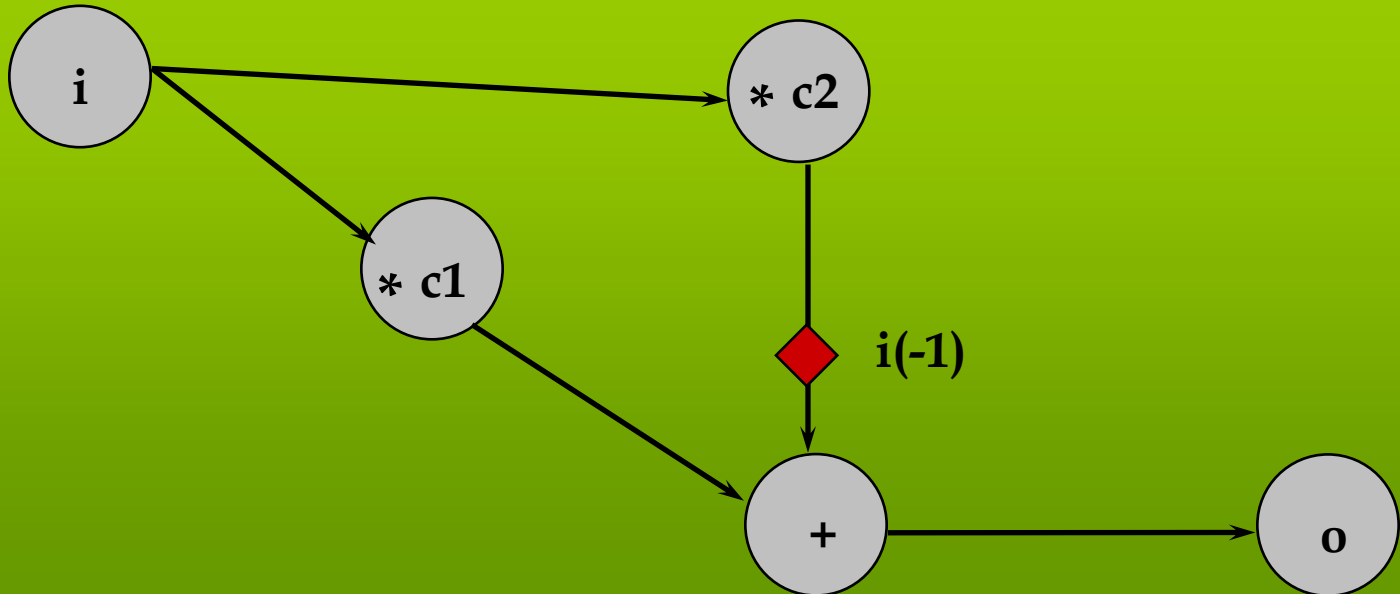

Intuitive semantics

- Example: FIR filter
 - single input sequence $i(n)$
 - single output sequence $o(n)$
 - $o(n) = c1 i(n) + c2 i(n-1)$

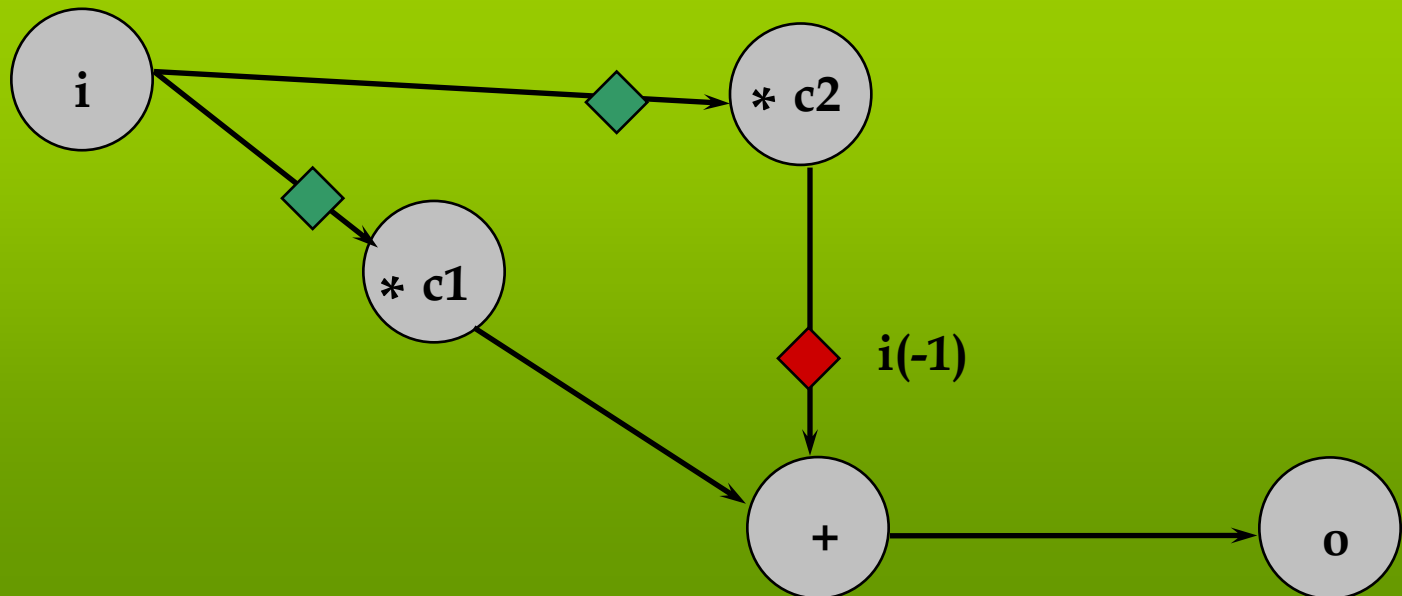

Intuitive semantics

- Example: FIR filter
 - single input sequence $i(n)$
 - single output sequence $o(n)$
 - $o(n) = c1 i(n) + c2 i(n-1)$

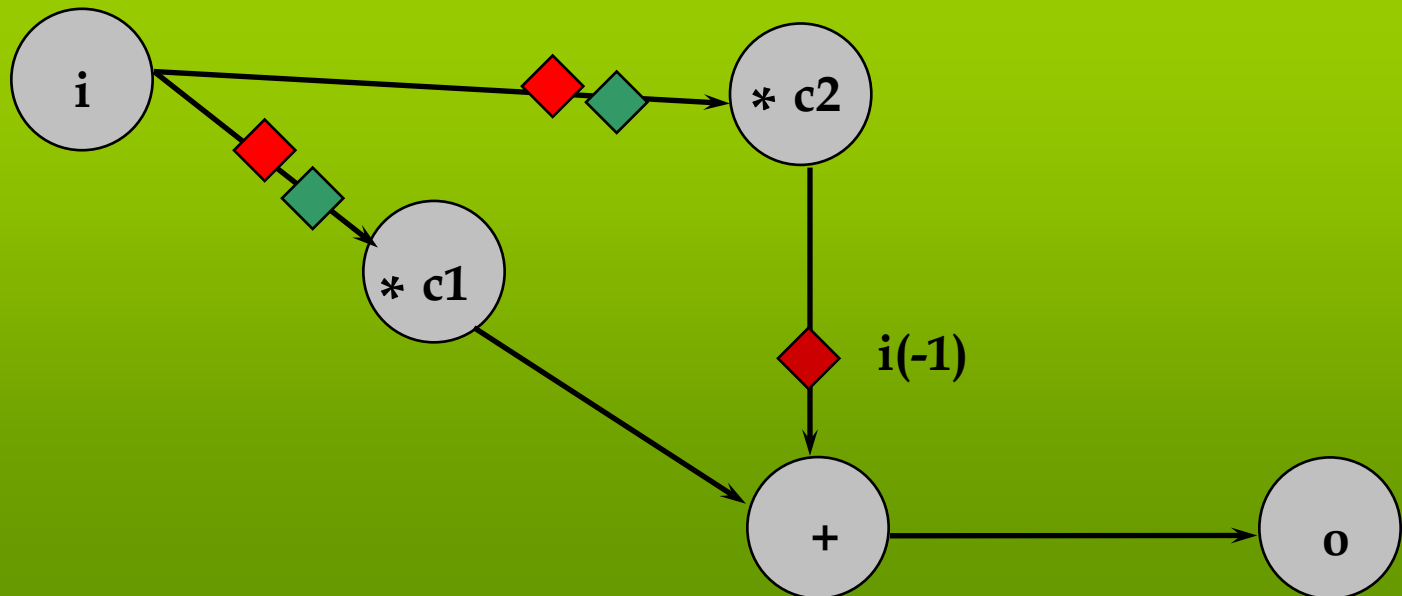

Intuitive semantics

- Example: FIR filter
 - single input sequence $i(n)$
 - single output sequence $o(n)$
 - $o(n) = c1 i(n) + c2 i(n-1)$

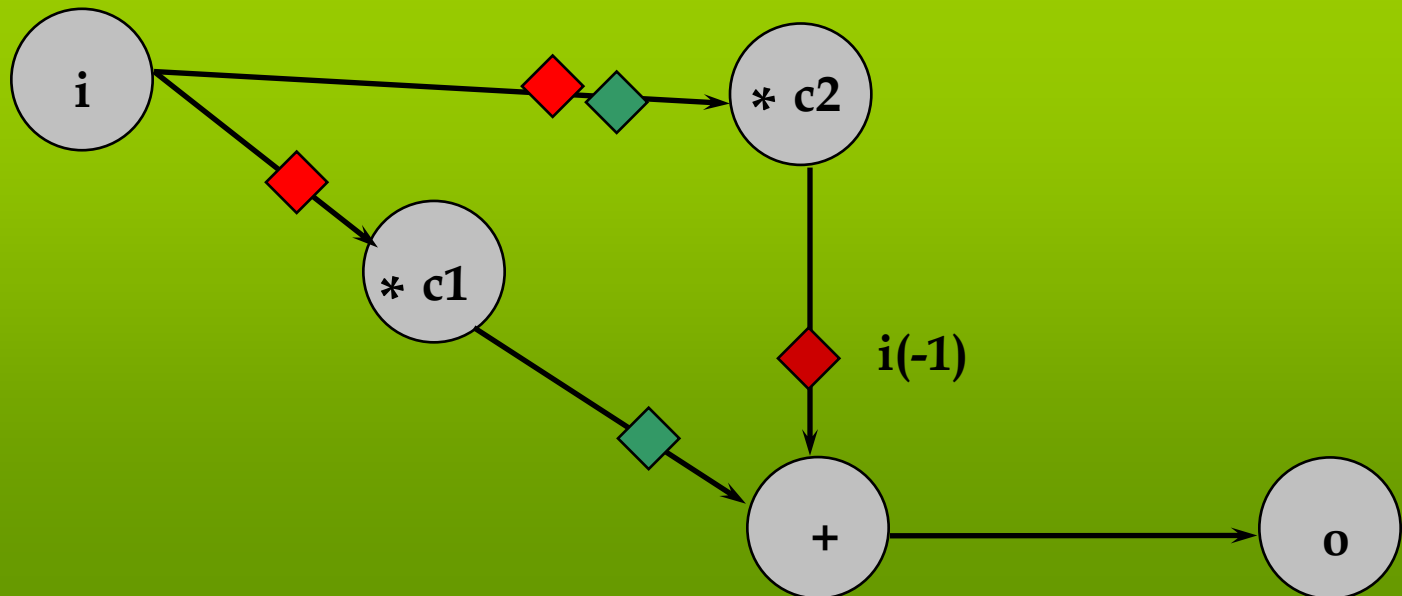

Intuitive semantics

- Example: FIR filter
 - single input sequence $i(n)$
 - single output sequence $o(n)$
 - $o(n) = c1 i(n) + c2 i(n-1)$

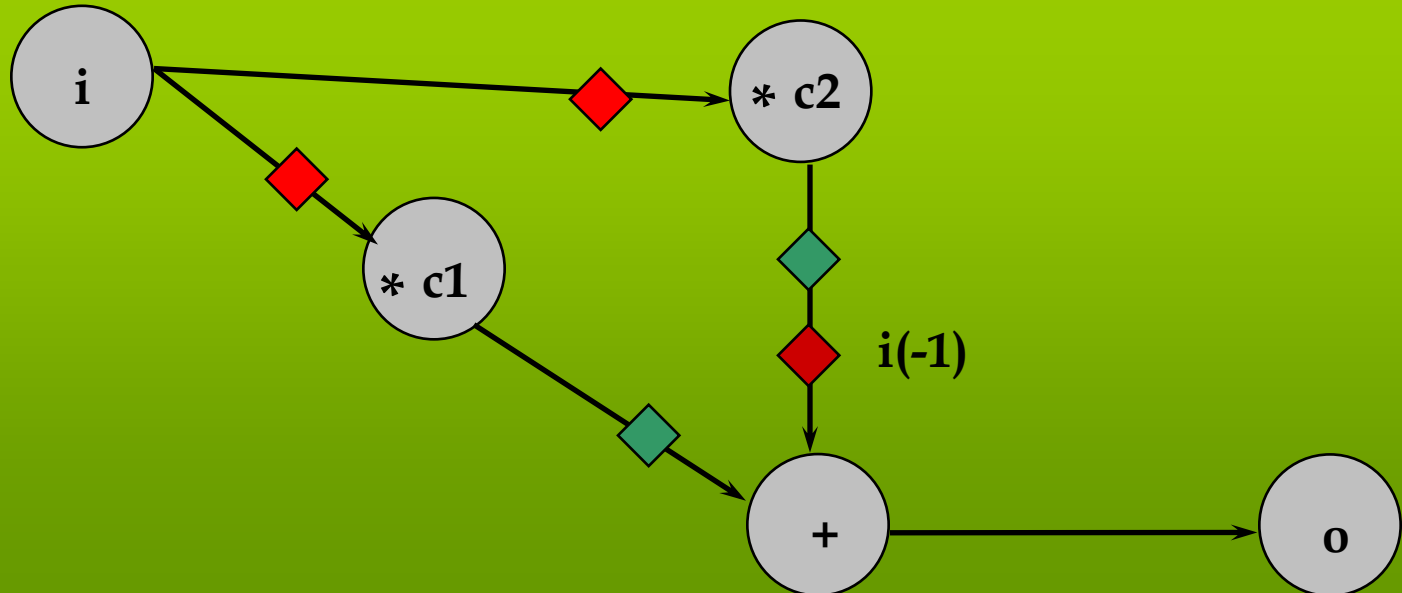

Intuitive semantics

- Example: FIR filter
 - single input sequence $i(n)$
 - single output sequence $o(n)$
 - $o(n) = c1 i(n) + c2 i(n-1)$

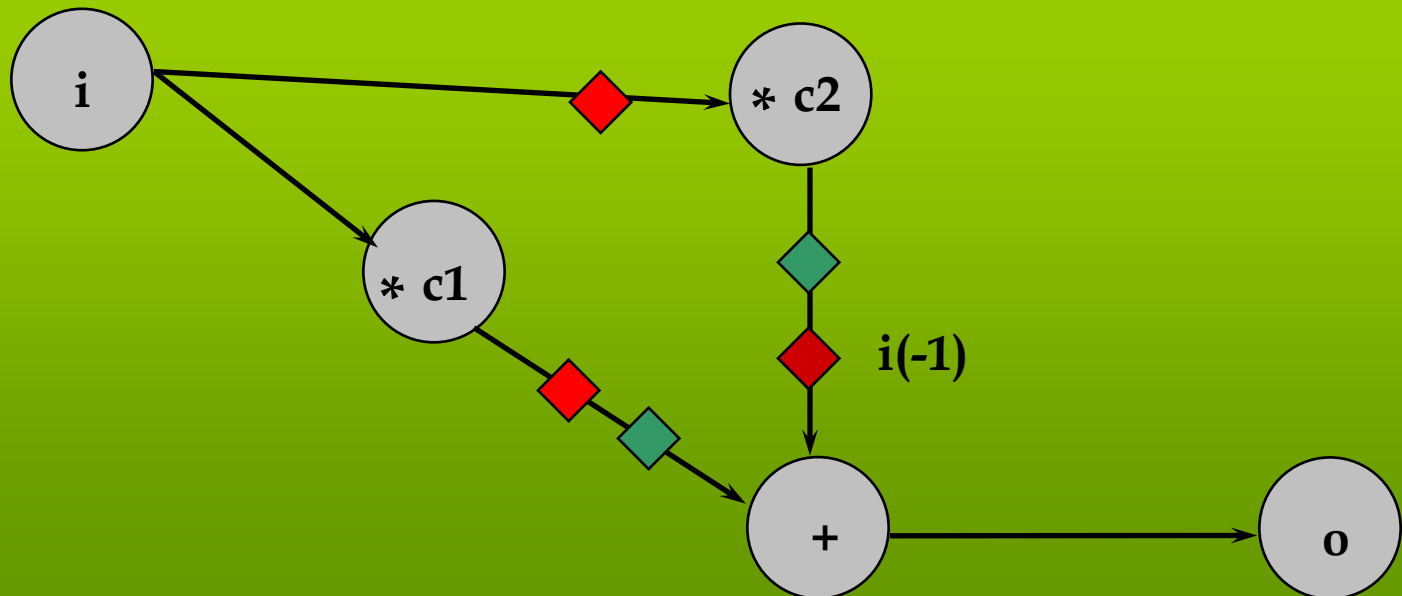

Intuitive semantics

- Example: FIR filter
 - single input sequence $i(n)$
 - single output sequence $o(n)$
 - $o(n) = c1 i(n) + c2 i(n-1)$

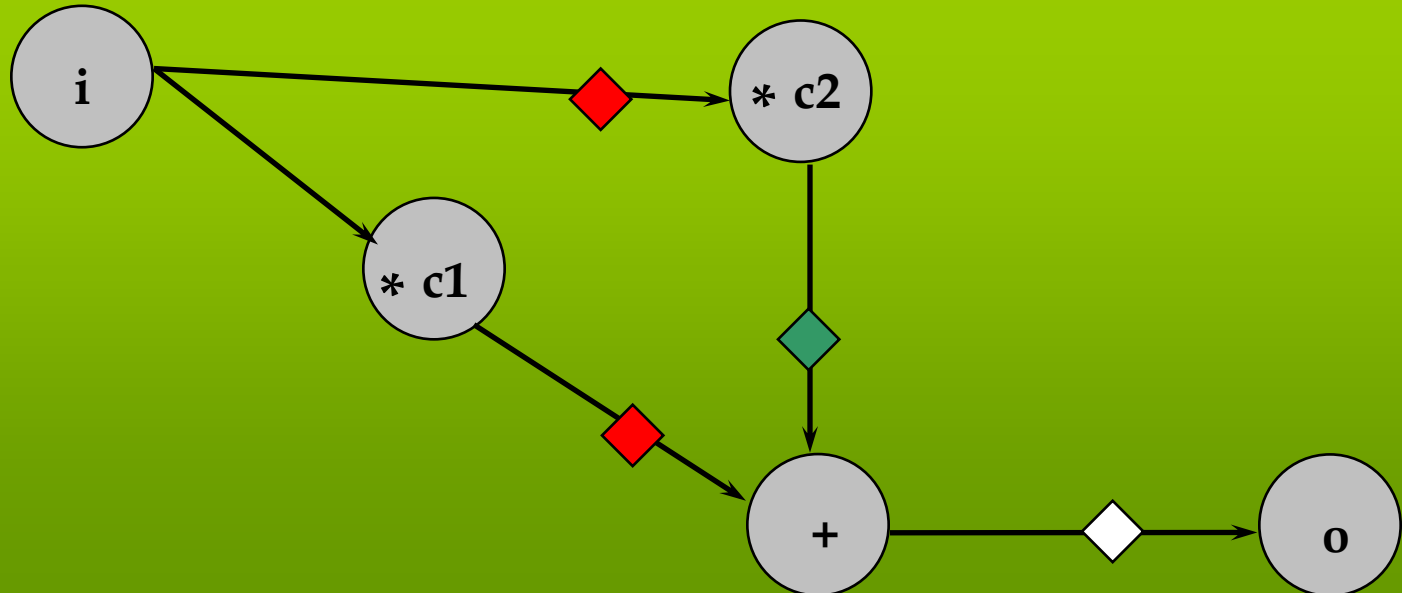

Intuitive semantics

- Example: FIR filter
 - single input sequence $i(n)$
 - single output sequence $o(n)$
 - $o(n) = c1 i(n) + c2 i(n-1)$

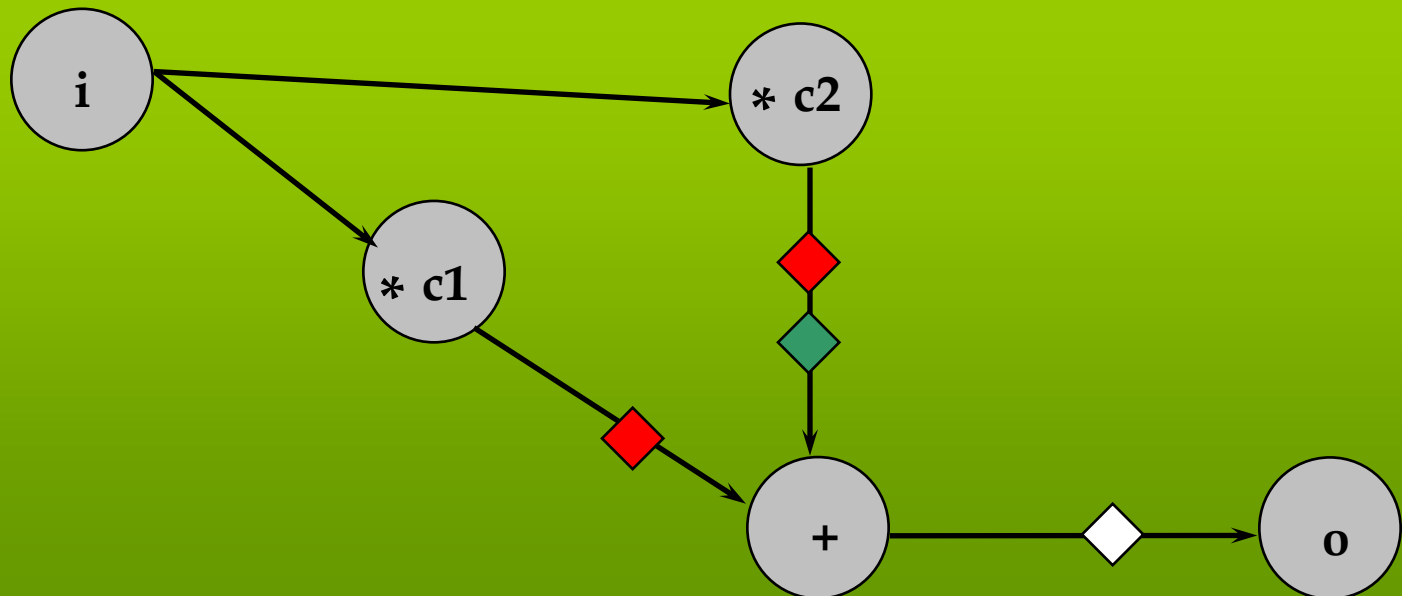

Intuitive semantics

- Example: FIR filter
 - single input sequence $i(n)$
 - single output sequence $o(n)$
 - $o(n) = c1 i(n) + c2 i(n-1)$

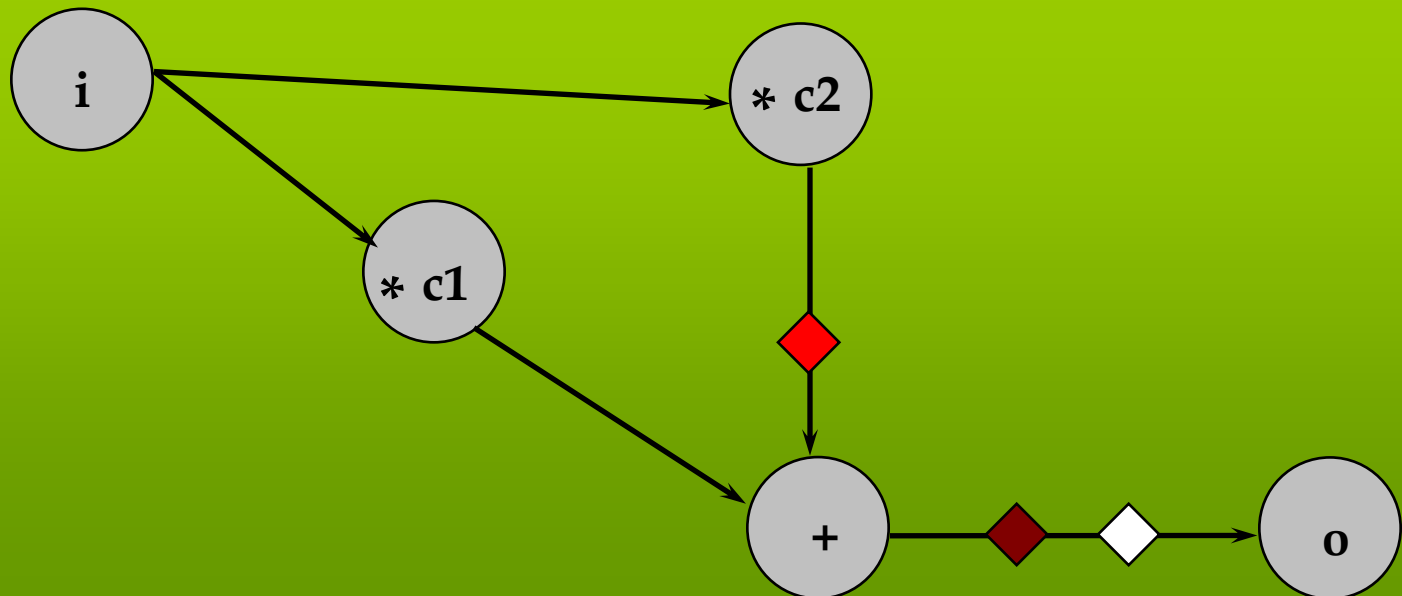

Intuitive semantics

- Example: FIR filter
 - single input sequence $i(n)$
 - single output sequence $o(n)$
 - $o(n) = c1 i(n) + c2 i(n-1)$

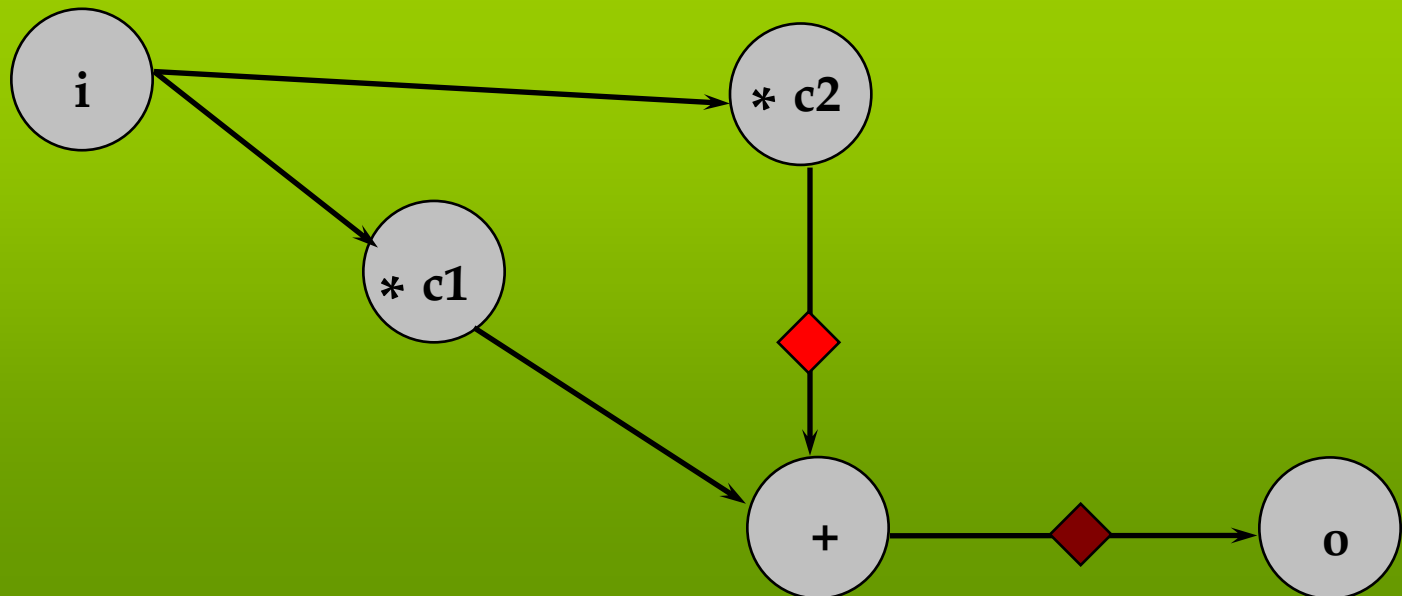

Questions



- Does the order in which actors are fired affect the final result?
- Does it affect the “operation” of the network in any way?
- Go to Radio Shack and ask for an unbounded queue!!



Formal semantics: sequences

- Actors operate from a **sequence** of input tokens to a **sequence** of output tokens
- Let tokens be noted by x_1, x_2, x_3 , etc...
- A **sequence** of tokens is defined as

$$X = [x_1, x_2, x_3, \dots]$$

- Over the execution of the network, each queue will grow a particular sequence of tokens
- In general, we consider the actors mathematically as functions from sequences to sequences (not from tokens to tokens)



Ordering of sequences

- Let X_1 and X_2 be two sequences of tokens.
- We say that X_1 is less than X_2 if and only if (by definition) X_1 is an initial segment of X_2
- Homework: prove that the relation so defined is a partial order (reflexive, antisymmetric and transitive)
- This is also called the prefix order
- Example: $[x_1, x_2] \leq [x_1, x_2, x_3]$
- Example: $[x_1, x_2]$ and $[x_1, x_3, x_4]$ are incomparable



Chains of sequences

- Consider the set S of all finite and infinite sequences of tokens
- This set is partially ordered by the prefix order
- A subset C of S is called a **chain** iff all pairs of elements of C are **comparable**
- If C is a chain, then it must be a **linear order** inside S (otherwise, why call it chain?)
- Example: $\{ [x_1], [x_1, x_2], [x_1, x_2, x_3], \dots \}$ is a chain
- Example: $\{ [x_1], [x_1, x_2], [x_1, x_3], \dots \}$ is not a chain



(Least) Upper Bound

- Given a subset Y of S , an **upper bound** of Y is an element z of S such that z is **larger** than all elements of Y
- Consider now the set Z (subset of S) of all the upper bounds of Y
- If Z has a least element u , then u is called the **least upper bound** (lub) of Y
- The least upper bound, if it exists, is unique
- Note: u might not be in Y (if it is, then it is the largest value of Y)



Complete Partial Order

- Every chain in S has a least upper bound
- Because of this property, S is called a **Complete Partial Order**
- Notation: if C is a chain, we indicate the least upper bound of C by $\text{lub}(C)$
- Note: the least upper bound may be thought of as the limit of the chain



Processes

- Process: function from a p -tuple of sequences to a q -tuple of sequences

$$F : S^p \rightarrow S^q$$

- Tuples have the induced point-wise order:

$Y = (y_1, \dots, y_p)$, $Y' = (y'_1, \dots, y'_p)$ in S^p : $Y \leq Y'$ iff $y_i \leq y'_i$ for all $1 \leq i \leq p$

- Given a chain C in S^p , $F(C)$ may or may not be a chain in S^q
- We are interested in conditions that make that true



Continuity and Monotonicity

- Continuity: F is continuous iff (by definition) for all chains C , $\text{lub}(F(C))$ exists and

$$F(\text{lub}(C)) = \text{lub}(F(C))$$

- Similar to continuity in analysis using limits
- Monotonicity: F is monotonic iff (by definition) for all pairs X, X'
 $X \leq X' \Rightarrow F(X) \leq F(X')$

- Continuity implies monotonicity

- intuitively, outputs cannot be “withdrawn” once they have been produced
- timeless causality. F transforms chains into chains



Least Fixed Point semantics

- Let X be the set of all sequences
- A network is a mapping F from the sequences to the sequences

$$X = F(X, I)$$

- The behavior of the network is defined as the **unique least fixed point** of the equation
- If F is continuous then the least fixed point exists $LFP = LUB(\{ F^n(\perp, I) : n \geq 0 \})$



From Kahn networks to Data Flow networks

- Each process becomes an *actor*: set of pairs of
 - firing rule
(number of required tokens on inputs)
 - function
(including number of consumed and produced tokens)
- Formally shown to be equivalent, but actors with firing are more intuitive
- *Mutually exclusive* firing rules imply monotonicity
- Generally simplified to *blocking read*

Examples of Data Flow actors

- SDF: Synchronous (or, better, Static) Data Flow
 - fixed input and output tokens

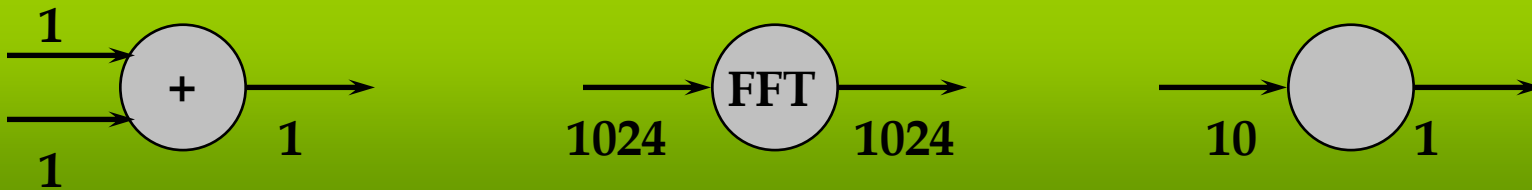

- BDF: Boolean Data Flow

- control token determines consumed and produced tokens

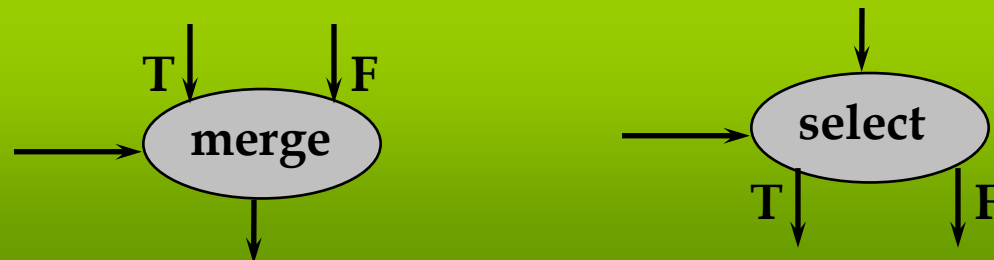



Static scheduling of DF

- Key property of DF networks: output sequences do not depend on *time of firing* of actors
- SDF networks can be *statically scheduled* at compile-time
 - execute an actor when it is *known* to be fireable
 - no overhead due to sequencing of concurrency
 - static buffer sizing
- Different schedules yield different
 - code size
 - buffer size
 - pipeline utilization



Static scheduling of SDF

- Based only on *process graph* (ignores functionality)
- Network state: number of tokens in FIFOs
- Objective: find schedule that is *valid*, i.e.:
 - *admissible*
(only fires actors when fireable)
 - *periodic*
(brings network back to initial state firing each actor at least once)
- Optimize cost function over admissible schedules

Balance equations

- Number of produced tokens must equal number of consumed tokens on every edge



- Repetitions (or firing) vector v_S of schedule S : number of firings of each actor in S
- $v_S(A) n_p = v_S(B) n_c$
must be satisfied for each edge

Balance equations

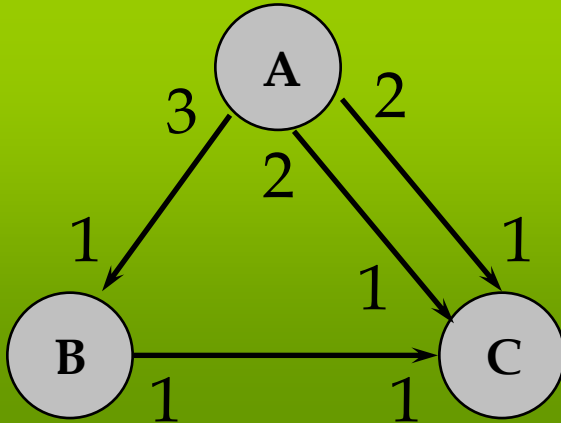

- Balance for each edge:

$$- 3 v_S(A) - v_S(B) = 0$$

$$- v_S(B) - v_S(C) = 0$$

$$- 2 v_S(A) - v_S(C) = 0$$

$$- 2 v_S(A) - v_S(C) = 0$$

Balance equations

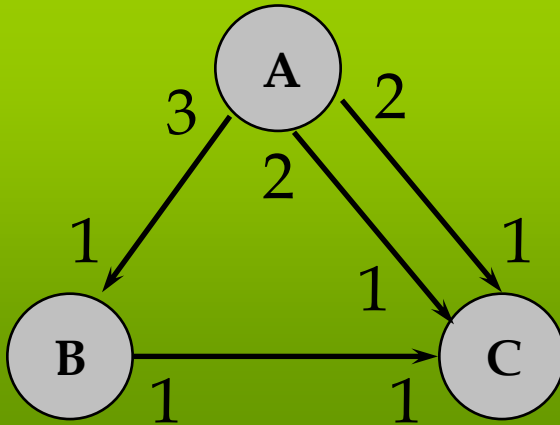

$$M = \begin{vmatrix} 3 & -1 & 0 \\ 0 & 1 & -1 \\ 2 & 0 & -1 \\ 2 & 0 & -1 \end{vmatrix}$$

- $M v_S = 0$
iff S is periodic
- Full rank (as in this case)
 - no non-zero solution
 - no periodic schedule
 (too many tokens accumulate on $A \rightarrow B$ or $B \rightarrow C$)

Balance equations

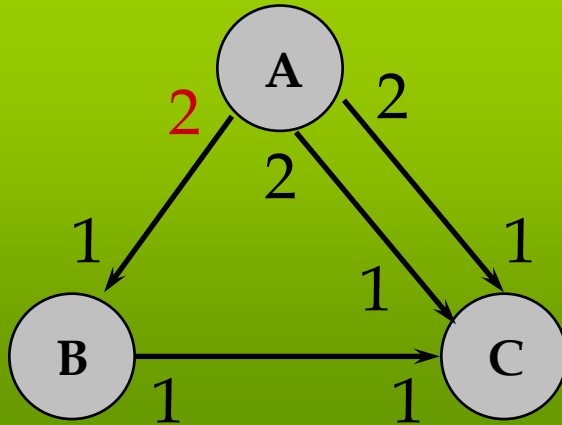

$$M = \begin{vmatrix} 2 & -1 & 0 \\ 0 & 1 & -1 \\ 2 & 0 & -1 \end{vmatrix}$$

- Non-full rank
 - infinite solutions exist (linear space of dimension 1)
- Any multiple of $q = [1 \ 2 \ 2]^T$ satisfies the balance equations
- ABCBC and ABBCC are minimal valid schedules
- ABABBCBCCC is non-minimal valid schedule



Static SDF scheduling

- Main SDF scheduling theorem (Lee '86):
 - A connected SDF graph with n actors has a periodic schedule iff its topology matrix M has rank $n-1$
 - If M has rank $n-1$ then there exists a unique smallest integer solution q to
$$M q = 0$$
- Rank must be at least $n-1$ because we need at least $n-1$ edges (connected-ness), providing each a linearly independent row
- Admissibility is not guaranteed, and depends on initial tokens on *cycles*

Admissibility of schedules

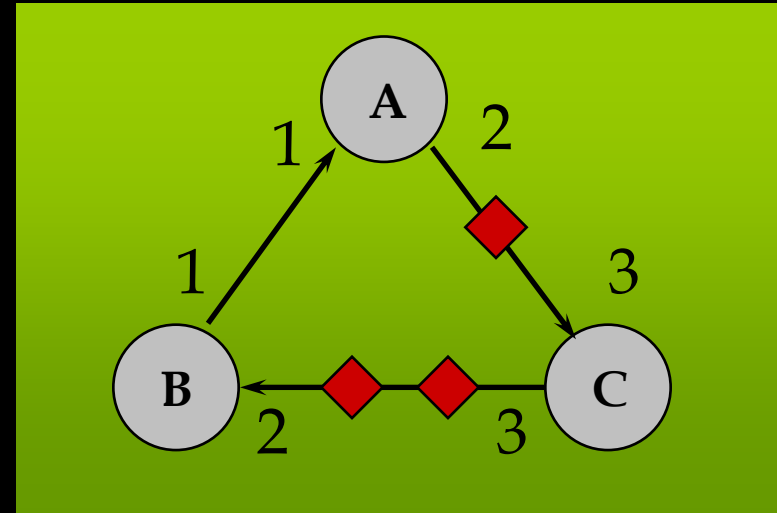

- No admissible schedule:
BACBA, then deadlock...
- Adding one token (delay) on A→C makes
BACBACBA valid
- Making a periodic schedule admissible is always possible, but
changes specification...



Admissibility of schedules

- Adding initial token changes FIR order

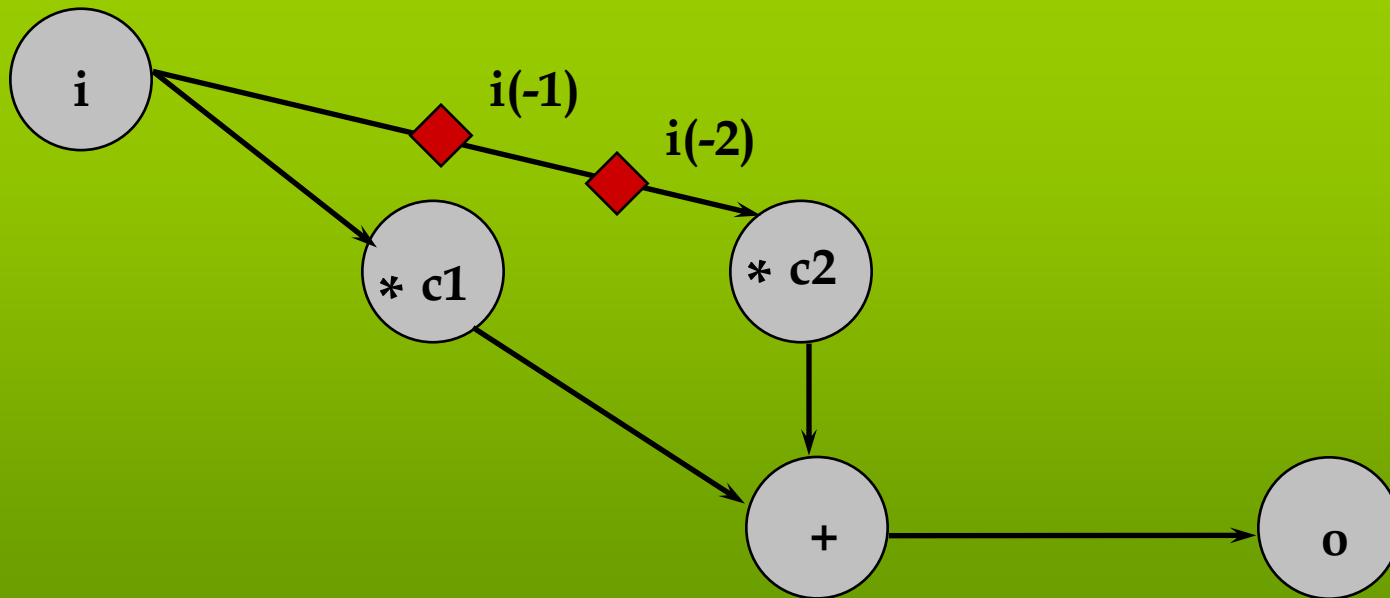

From repetition vector to schedule

- Repeatedly schedule fireable actors up to number of times in repetition vector

$$q = |1 \ 2 \ 2|^T$$

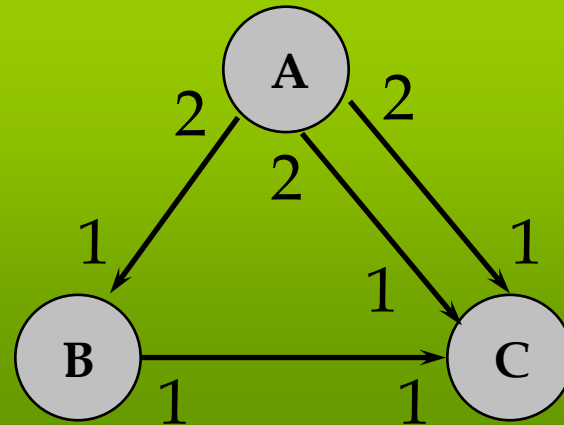

- Can find either ABCBC or ABBCC
- If deadlock before original state, no valid schedule exists (Lee '86)



From schedule to implementation

- Static scheduling used for:
 - behavioral simulation of DF (extremely efficient)
 - code generation for DSP
 - HW synthesis (Cathedral by IMEC, Lager by UCB, ...)
- Issues in code generation
 - execution speed (pipelining, vectorization)
 - code size minimization
 - data memory size minimization (allocation to FIFOs)
 - processor or functional unit allocation



Compilation optimization

- Assumption: *code stitching*
(chaining custom code for each actor)
- More efficient than C compiler for DSP
- Comparable to hand-coding in some cases
- Explicit parallelism, no artificial control dependencies
- Main problem: memory and processor/FU allocation depends on scheduling, and vice-versa



Code size minimization

- Assumptions (based on DSP architecture):
 - subroutine calls expensive
 - fixed iteration loops are cheap
(“zero-overhead loops”)
- Absolute optimum: *single appearance schedule*
e.g. ABCBC → A (2BC), ABBCC → A (2B) (2C)
 - may or may not exist for an SDF graph...
 - buffer minimization relative to single appearance schedules
(Bhattacharyya '94, Lauwereins '96, Murthy '97)

Buffer size minimization

- Assumption: no buffer sharing
- Example:

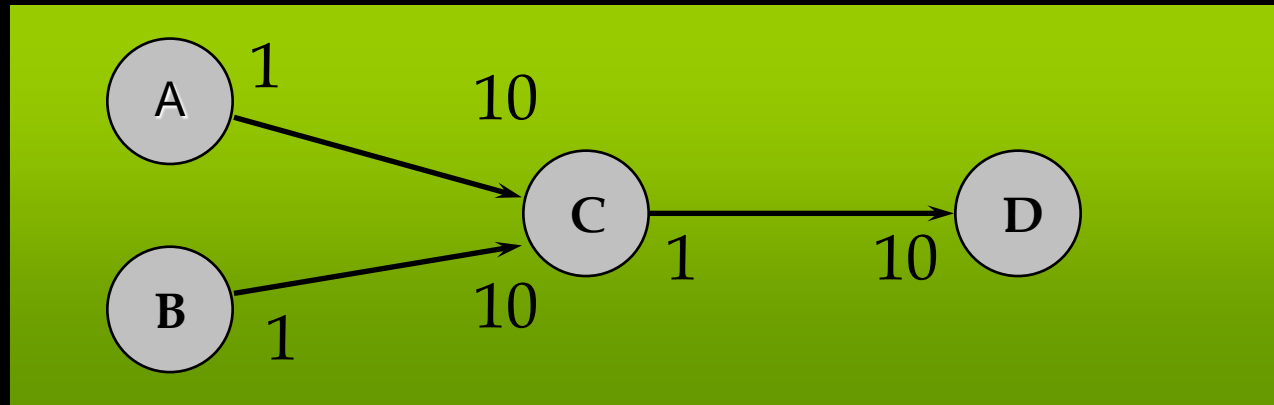

$$q = |100 \ 100 \ 10 \ 1|^T$$

- Valid SAS: (100 A) (100 B) (10 C) D
 - requires 210 units of buffer area
- Better (factored) SAS: (10 (10 A) (10 B) C) D
 - requires 30 units of buffer areas, but...
 - requires 21 loop initiations per period (instead of 3)



Dynamic scheduling of DF

- SDF is limited in modeling power
 - no run-time choice
 - cannot implement Gaussian elimination with pivoting
- More general DF is too powerful
 - non-Static DF is Turing-complete (Buck '93)
 - bounded-memory scheduling is not always possible
- BDF: semi-static scheduling of special “patterns”
 - if-then-else
 - repeat-until, do-while
- General case: thread-based dynamic scheduling
 - (Parks '96: may not terminate, but never fails if feasible)

Example of general DF

- Merge streams of multiples of 2 and 3 in order (removing duplicates)

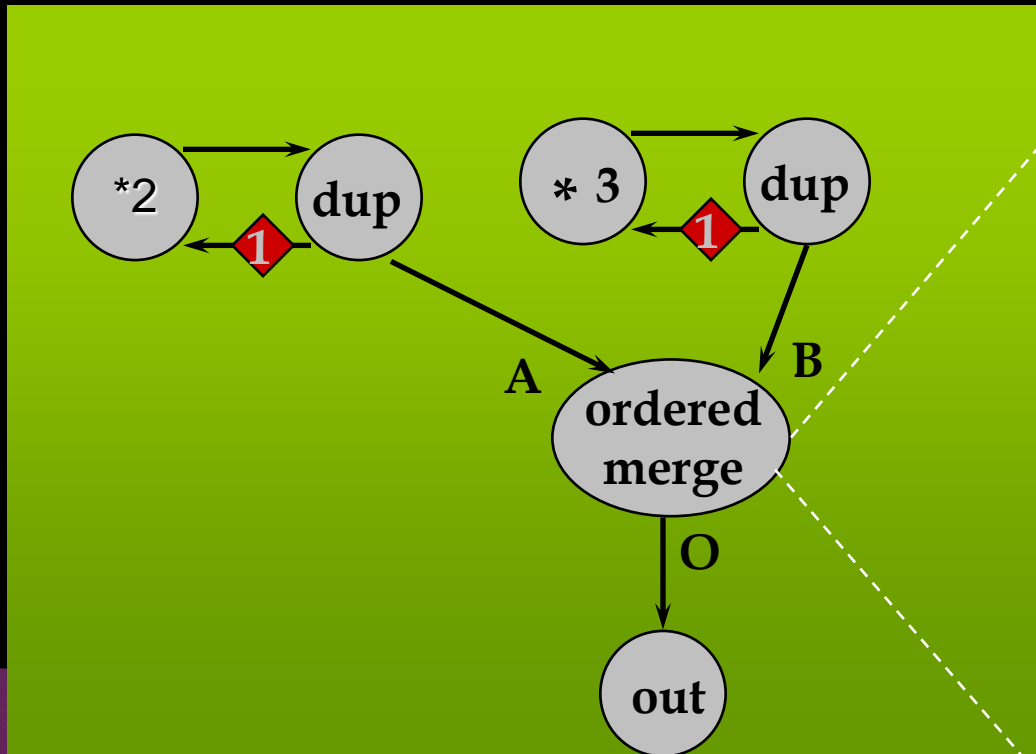

```
a = get (A)
b = get (B)
forever {
  if (a > b) {
    put (O, a)
    a = get (A)
  } else if (a < b) {
    put (O, b)
    b = get (B)
  } else {
    put (O, a)
    a = get (A)
    b = get (B)
  }
}
```

- Deterministic merge
(no “peeking”)



Summary of DF networks

- Advantages:
 - Easy to use (graphical languages)
 - Powerful algorithms for
 - verification (fast behavioral simulation)
 - synthesis (scheduling and allocation)
 - Explicit concurrency
- Disadvantages:
 - Efficient synthesis only for restricted models
 - (no input or output choice)
 - Cannot describe reactive control (blocking read)

Base-band Processing in Cell Phones

Frame to transmit (stream of bits)

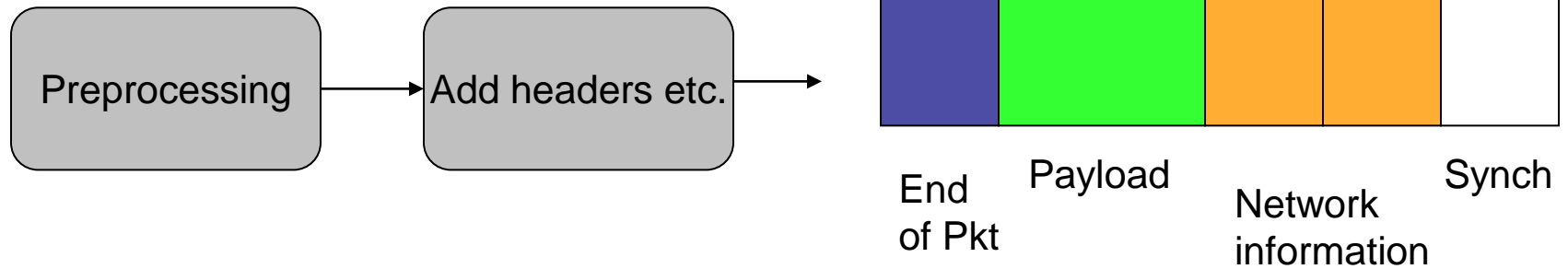

Mapping on a Constellation (QPSK)

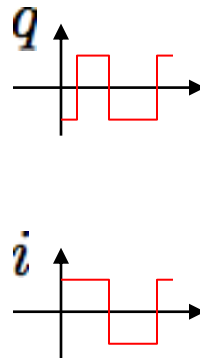
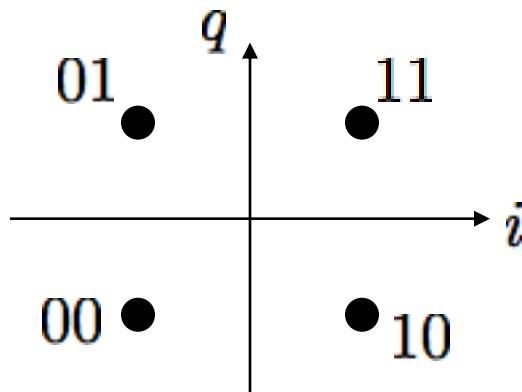

Filtering

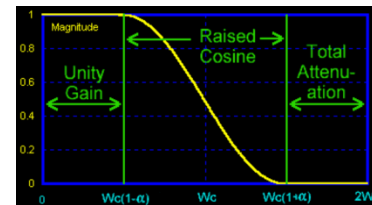
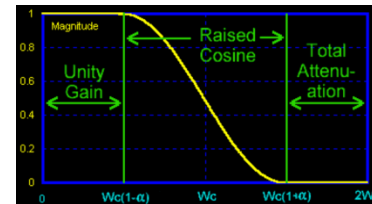

Modulation

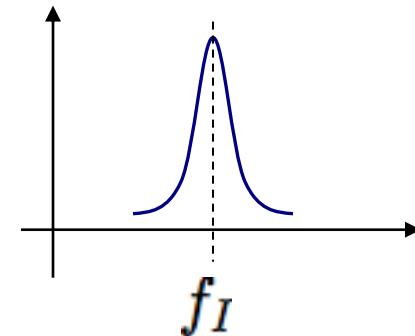

Base-band Processing: Denotation

Composition of functions = overall base-band specification

$$x[n] = (Map_i(s) * h)[n] \sin(2\pi f_I nT) + (Map_q(s) * h)[n] \cos(2\pi f_I nT)$$

$$i[n] = Map_i(s[n])$$

$$q[n] = Map_q(s[n])$$

$$i_f[n] = \sum_{k=1}^N h[k-1] i_f[n-k]$$

$$q_f[n] = \sum_{k=1}^N h[k-1] q_f[n-k]$$

$$x[n] = i_f[n] \sin(2\pi f_I nT) + q_f[n] \cos(2\pi f_I nT)$$

Mapping on a Constellation (QPSK)

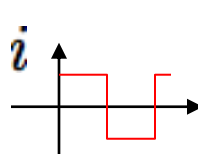
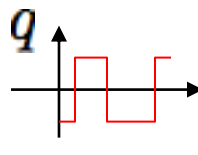
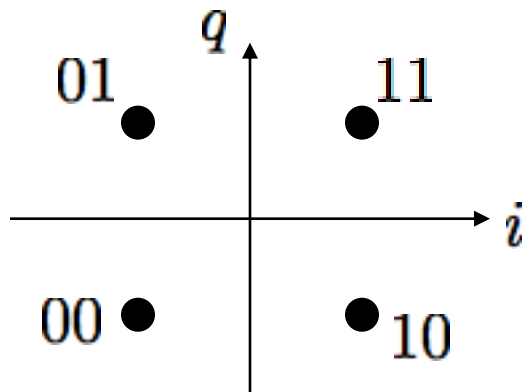

Filtering

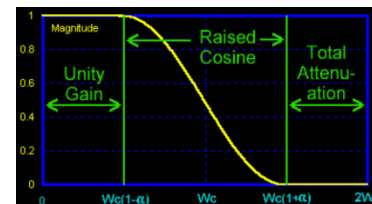
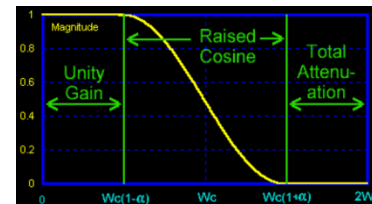

Modulation

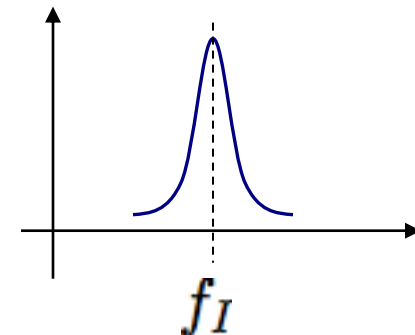

Base-band Processing: Data Flow Model

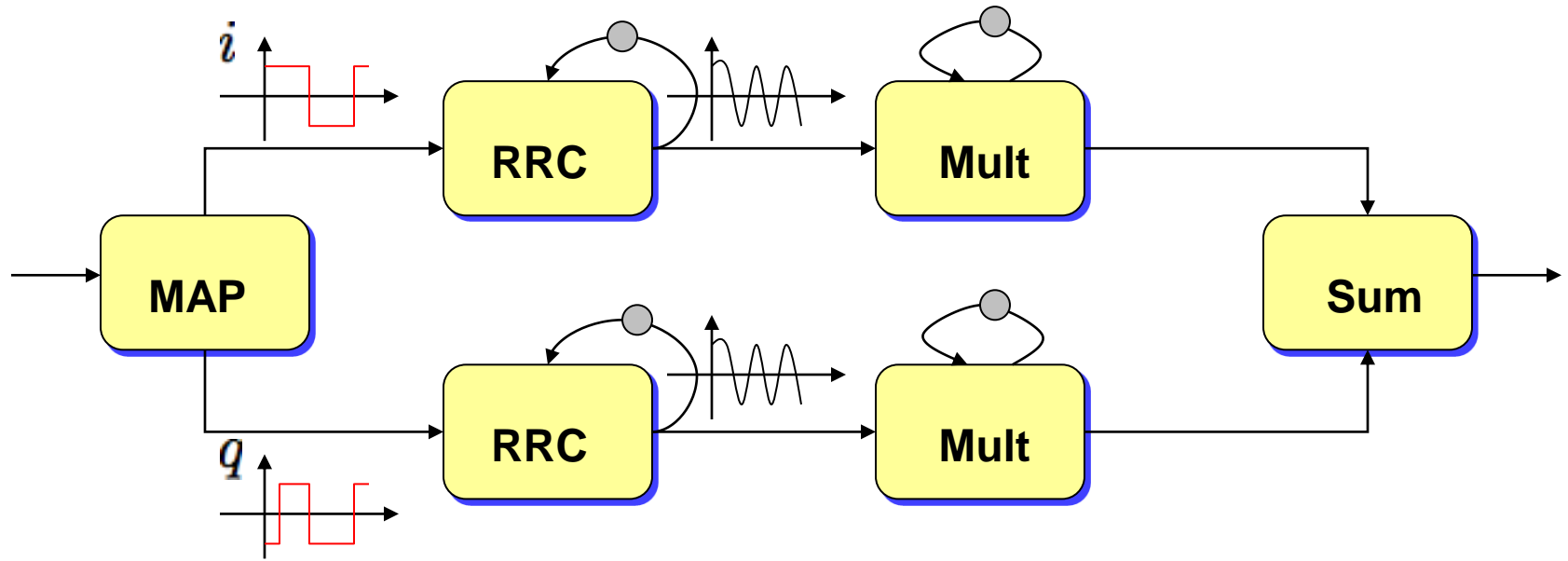

Mapping on a Constellation (QPSK)

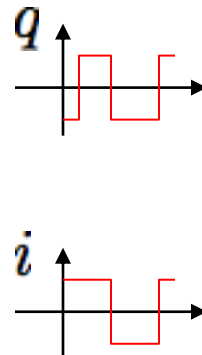
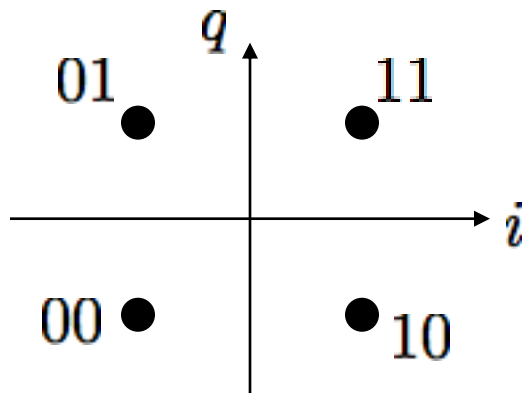

Filtering

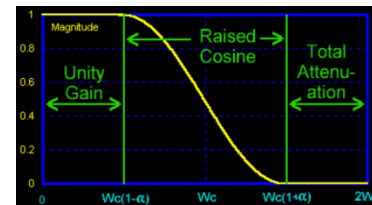
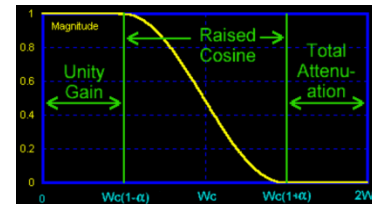

Modulation

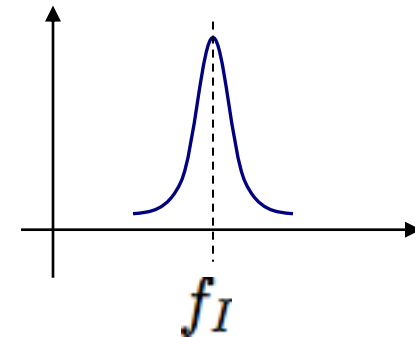



Remarks

- Composition is achieved by input-output connection through communication channels (FIFOs)
- The operational semantics dictates the conditions that must be satisfied to execute a function (actor)
- Functions operating on streams of data rather than states evolving in response to traces of events (data vs. control)
- Convenient to mix denotational and operational specifications

Telecom/MM applications



- Heterogeneous specifications including
 - data processing
 - control functions
- Data processing, e.g. encryption, error correction...
 - computations done at regular (often short) intervals
 - efficiently specified and synthesized using DataFlow models
- Control functions (data-dependent and real-time)
 - say when and how data computation is done
 - efficiently specified and synthesized using FSM models
- Need a common model to perform global system analysis and optimization



Mixing the two models: 802.11b

- State machine for control
 - Denotational: processes as sequence of events, sequential composition, choice etc.
 - Operational: state transition graphs
- Data Flow for signal processing
 - Functions
 - Data flow graphs
- And what happens when we put them together?



802.11b: Modes of operation

Data rate (Mbit/s)	Modulation	Coding rate	<i>N</i> dbps	1472 byte transfer duration(μ s)
6	BPSK	1/2	24	2012
9	BPSK	3/4	36	1344
12	QPSK	1/2	48	1008
18	QPSK	3/4	72	672
24	16-QAM	1/2	96	504
36	16-QAM	3/4	144	336
48	64-QAM	2/3	192	252
54	64-QAM	3/4	216	224

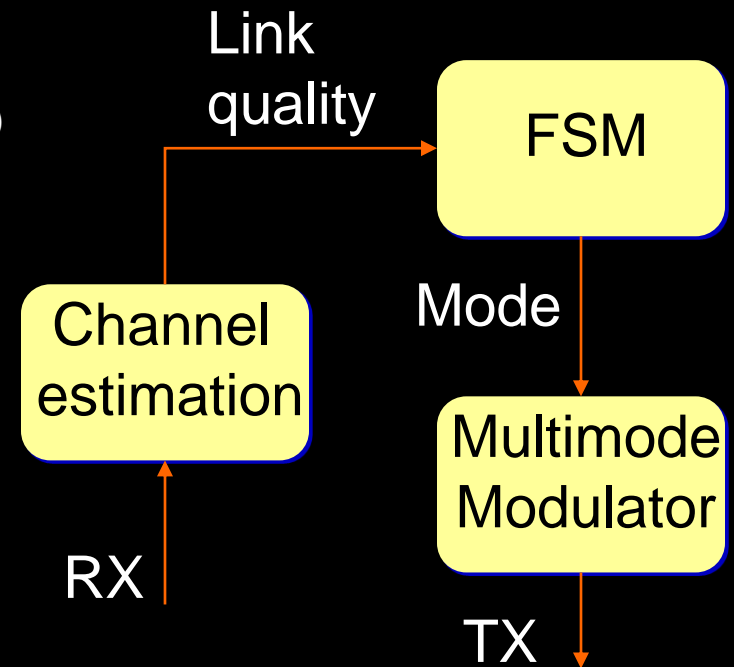

- Depending on the channel conditions, the modulation scheme changes
- It is natural to mix FSM and DF (like in figure)
- Note that now we have real-time constraints on this system (i.e. time to send 1472 bytes)

Outline



- Part 3: Models of Computation
 - FSMs
 - Discrete Event Systems
 - CFSMs
 - Data Flow Models
 - **Petri Nets**
 - The Tagged Signal Model